



TOMARK s.r.o.
Division
TOMARKAERO / TOMARKAERO CZ

MANDATORY BULLETIN

Závazný bulletin

Number: ZB SD4-01-2012
Číslo:

Name/Subject: A modification of the installation of the control pull-push rods of the front gear leg
Názov/Predmet:

Models affected: all models of the Viper SD-4 aircraft manufactured by 20.8.2012
Týka sa:

Reason of issuance: design modification of the attachment of the push-pull rods of the front gear leg
Dôvod vydania:

Time of compliance: by the end of the nearest periodical inspection of the aircraft
Vykonať najneskôr do:

To be done by: Tomark s.r.o. – Aero Division or the operator of the aircraft
Vykoná: in cooperation with the Tomark s.r.o. Service Centre

Work procedure: in accordance with the Change Order No. PR – 25/2012
Postup vykonania prác:

Costs covered by: Tomark s.r.o. – Aero Division
Náklady hradí:

Required material supplied by: Tomark s.r.o. – Aero Division
Potrebný materiál dodá:

Date of issuance: 28.9.2012
Dátum vydania:

Date approval: 28.9.2012
Schválené dňa:

Approved by: Slavomír Dobrovič, Eng., Chief Designer of Aero Division, Tomark s.r.o.
Schválil:

Number of pages 1 + 2
Počet listov:



Slavomír Dobrovič, Eng.
Chief Designer of Aero Division, Tomark s.r.o.

WORK PROCEDURE

In accordance with the Change Order No. PR – 25/2012

Description:

Design modification of the attachment of the pull-push rods of the control of the front gear leg applicable to customers (aircraft owners) who will carry out the modification themselves.

Description of the change (see Fig. 3)
– in the case a bearing eye Ø6 is installed.

- 1) Change of push-pull rod
TIAHLO_PODVOZOK_N
- 2) Addition of an insert F_GEAR_VLOZKA
- 3) Addition of 1.2 mm thick stainless steel washers 6x20
- 4) Addition of 1.2 mm thick stainless steel washers 6x12
- 5) Replacement of M6x55 bolt with a hex socket head

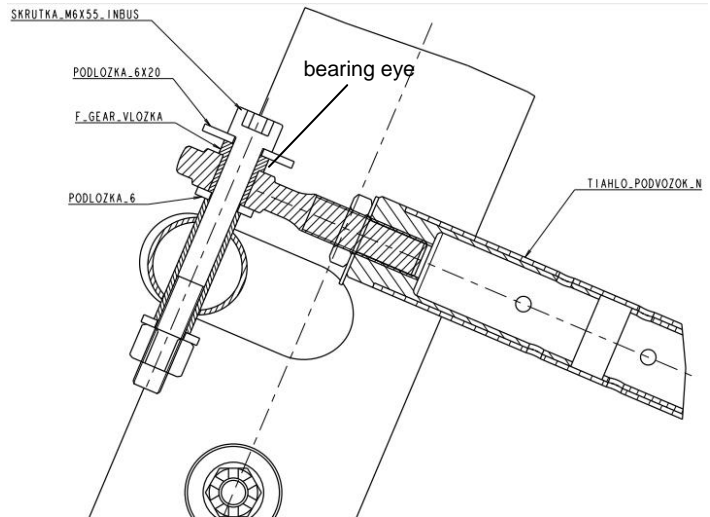

Fig. 3

Work procedure:

- On the right side, demount the push-pull control rod of the front landing gear (TIAHLO_PODVOZOK_N).
- On the new supplied push-pull rod set the axis distance between the bearing eye and the adjustable fork according to the original setting, i.e. according to the demounted push-pull rod.
- Tighten the counter-nuts on both sides of the push-pull rod and lock their position by bending the washer tag.
- Install the new push-pull rod (TIAHLO_PODVOZOK_N) (with the adjusted axis distance).

Notes:

- 1) On the side of the lever (rudder pedals), use again the demounted connection elements and lock them with a locking pin.
- 2) On the side of the front gear leg, use the supplied connection elements.

CAUTION: Replace the demounted M6 self-locking nut with a new supplied M6 self-locking nut. The nut may be used only once.

- Proceed likewise on the left side of the control of the front landing gear leg (left push-pull rod).
- Finally, check visually the alignment of the front landing gear leg with the rudder and the rudder pedals, i.e. whether the rudder pedals, the front landing gear leg and the rudder are simultaneously in the neutral position.

Design modification of the attachment of the pull-push rod of the control of the front gear leg applicable to customers (aircraft owners) who will carry out the modification themselves.

Description of the change (see fig. 4) – in the case a Ø8 bearing eye is installed.

1.) Addition of a washer PODLOZKA_M8x20

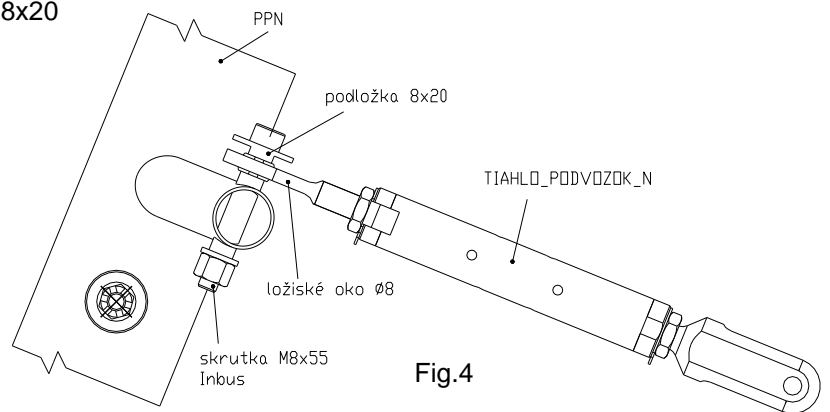

Work procedure:

- On the right side demount the M8 bolt with a hex socket head.
- Put the supplied washer PODLOZKA_M8x20 on the supplied M8x55 bolt with a hex socket head.
- Mount the push-pull rod TIAHLO_PODVOZOK_N“ on the front landing gear.

CAUTION: Replace the demounted M8 self-locking nut with a new supplied M8 self-locking nut. The nut may be used only once.

Proceed likewise on the left side of the control of the front landing gear leg.

Informative drawing of the control of the front landing gear leg

